

R8001M1050, M1150, M4050, M4150 Actuator Mounting Kit for Maxon CV Series Valves

INSTALLATION INSTRUCTIONS

APPLICATION

This document provides installation instructions for mounting the R8001M1050, R8001M1150, R8001M4050, or R8001M4150 SLATE Low Torque Actuator to the Maxon CV series valve.

50123928-001 KIT CONTENTS

Item Number	Description	Qty
1	CV Adapter Bracket	1
2	1/4-in. SAE Flat Washer	1
3	1/4-in. 20 Flanged Button Head Hex Socket Screw, Zinc Plated	1
4	1/4-in. Split Lock Washers, Zinc Plated	9
5	1/4-in. 20 Hex Nut, Zinc Plated	1
6	.5–.375 in. Valve Coupling Assembly	1
10	Drop Mount Bracket	1
11	M6 Flat Washers, Zinc Plated	4
12	M6x10 Hex Head Cap Screws	4
13	1/4-in. 20 Slotted Round Head Screws, Zinc Plated	3
32-00033—01	Instruction Sheet (CV)	1

INSTALLATION



WARNING

Fire or Explosion Hazard.

Can cause serious injury or death.

Turn off gas supply upstream from the gas valve to prevent fire, explosion or asphyxiation hazard.

Follow these steps to use the mounting kit to directly connect the SLATE Low Torque Actuator to the Maxon CV series valve (see Fig. 1).

1. Turn off the fuel supply upstream from the applicable CV valve.
2. Remove all external hardware from the CV valve.

IMPORTANT

For 3/8-in. valve shafts align the adapter insert so that the insert allows the set screws to contact the shaft.

3. Attach drop mount bracket (Item 10) to SLATE Low Torque Actuator with the four Item 12 screws and four Item 11 flat washers. Do not tighten completely at this time.
4. Attach CV adapter bracket (Item 1) to CV valve with two or three Item 13 screws and Item 4 washers. Allow the bracket to slide at this time.
5. Insert SLATE Low Torque Actuator shaft into coupling.
6. Insert valve shaft into other end of coupling.
7. Tighten coupling set screws onto both shafts. All set screws should contact a shaft.
8. Insert Item 3 screw into drop mount bracket and CV adapter bracket.
9. Place Item 2 flat washer, Item 4 lock washer, and Item 5 hex nut on Item 3 screw and tighten.
10. Tighten Item 13 screws on CV adapter bracket.
11. Tighten Item 12 screws on drop mount bracket.
12. Follow instruction in form 32M-06009—01 to wire the SLATE Low Torque Actuator.
13. Restore fuel and power to system.



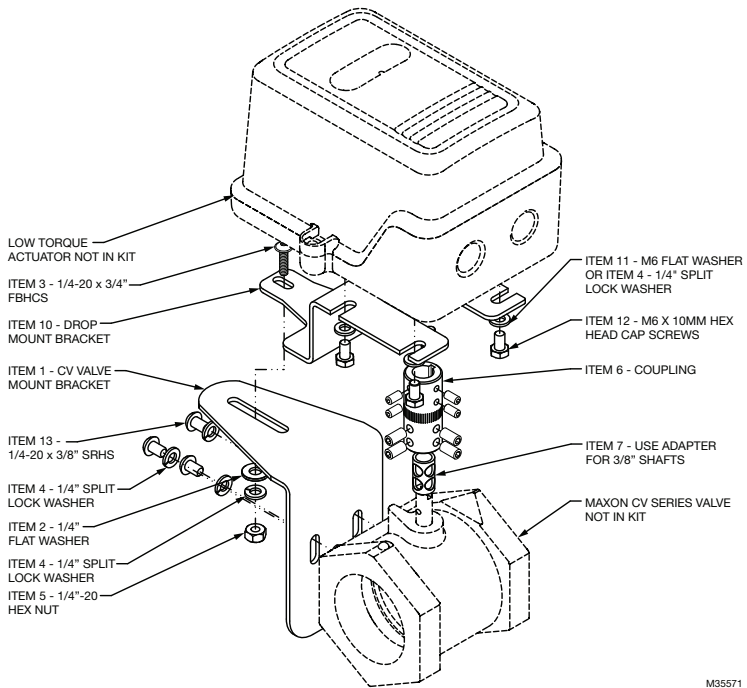

Fig. 1. Connecting the SLATE Low Torque Actuator to the CV series valve using the 50123928 Mounting Kit.

Automation and Control Solutions

Honeywell International Inc.
 1985 Douglas Drive North
 Golden Valley, MN 55422
 customer.honeywell.com



© U.S. Registered Trademark
 © 2015 Honeywell International Inc.
 32-00033—01 M.S. 06-15
 Printed in United States