

## Dual Flame Amplifier Support Available in SLATE SW Rev 3.10

In some applications involving long ribbon burners or applications where dissimilar flame sensing is required to insure the integrity of the flame signal, multiple flame sensors are needed. Until now, SLATE supported a single flame amplifier per each burner. With the release of SW 3.10, each SLATE burner module may support either a single amplifier or two amplifiers in any combination. The two flame sensors may be set up in an “OR” configuration where only one sensor is required to sense flame in order to keep the burner module satisfied (redundant configuration) or they may be set up in an “AND” configuration where both sensors must have viable flame signals in order for the sequence to remain uninterrupted. They can be monitored together or staggered in the burner sequence.

Redundant configurations (“OR”) can also be configured to only require one of two sensors to be functional. This may help maintain the burners firing should one of the amplifiers fail.

So, on a long ribbon burner where both ends must be continuously monitored or those applications where different sensing technology is needed to prove flame is present, the dual amplifier feature saves a lot of time and money.

The benefits of dual flame sensors/amplifiers extends to dual burner systems as well. Dual burners operating off a single main gas line can be easily managed using a single burner module and two amplifier modules. When configured in an “AND” configuration (S1 and S2), both burners must maintain flame signal in order for the burner module to avoid a lockout. Timing configurations in the burner module allows staggering of flame sensing in a dual amplifier system.

Example: The burner module controls two igniters and a single pilot/main valve train. This dual burner option saves one burner module as well as gas train components. It leverages SLATE’s ability to connect to two similar or different flame sensors and monitor the two burners individually to either keep both burners firing or to lock out, shutting down both burners on loss of flame from either burner.

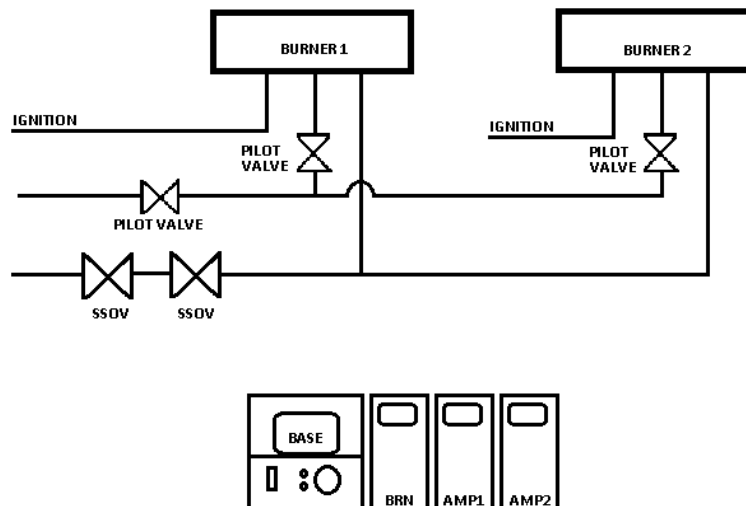

The dual-amplifier approach requires burner module configuration to support the feature as well as an additional physical setting on the amplifier module.

### Amplifier Module Configuration:

Each amplifier module has a setting switch on the back indicating the amplifier's position in a dual-amplifier application. The default factory setting is "1". The amplifier module which will occupy position two must be set to "2" using a small screw driver. The setting switch is located on the back of the Amplifier Module.



Amplifier Module Position Setting Switch

### Burner Module Configuration:

The dual-amplifier feature must also be configured in Niagara or in the generic pages. The configuration for multiple amplifier modules is found in the burner module configuration. The flame sensing must work in an "AND" configuration when BOTH amplifiers must read flame signals in order for both burners to fire. When flame signal redundancy is needed and two different sensors are required, the configuration is set to "OR" and both flame sensors must lose the flame signal for the burner module to lock out and the burners to stop firing.

#### Example:

In the configuration example below, two flame amplifiers are set up for a dual burner application. If either amplifier loses its signal at any time, the burner module must lock out.

The amplifier modules must function in an "AND" configuration with a 10 second maximum allowable delay between the first amplifier module flame detection and the second amplifier module flame detection in case the gas piping to the second burner pilot/main burner nozzle is farther from the source than the first burner pilot/main burner nozzle and may require a little more time to light off. Both scanners must be able to detect both the pilot and the main flames.

Name	Register Number	Setting	Help
Ignitor duration	126	Normal duration	Help
Ignition type	127	Interrupted pilot	Help
Flame sensing system type	128	Single flame sensor	Help
Secondary flame sensing time	129	Single flame sensor	Help
Pilot valve hold enable	131	Ignition:S1 Run:S2 Ignition:S1 Run:Combined S1 S2 Combined S1 S2	Help
Pilot valve hold transition time	132	10	Help
Manual open switch enable	133	Disable	Help
Auto ignition enable	134	Disable	Help
Delayed main valve 2 enable	135	Disabled	Help
Combination flame sensing	265	Not Combined	Help

Protect Mode

**Ignition: S1 Run:S2**-Sensor 1 is used only during Ignition while Sensor 2 is used in Run  
**Ignition: S1 Run: Combined S1 S2**-Sensor 1 is used during Ignition while both Sensor 1 and Sensor 2 are used during Run in an “AND” or an “OR” configuration to be defined in another parameter.

**Combined S1 S2**-Detection is done using both flame sensors during Ignition and Run in an “AND” or an “OR” configuration to be defined in another parameter.

For the requirement, the selection “Combined S1 S2” is made as both sensors are used during Ignition and Run.

Name	Register Number	Setting	Help
Ignitor duration	126	Normal duration	Help
Ignition type	127	Interrupted pilot	Help
Flame sensing system type	128	Combined S1 S2	Help
Secondary flame sensing time	129	0	Help
Pilot valve hold enable	131	Disable	Help
Pilot valve hold transition time	132	10	Help
Manual open switch enable	133	Disable	Help
Auto ignition enable	134	Disable	Help
Delayed main valve 2 enable	135	Disabled	Help
Combination flame sensing	265	Not Combined	Help

Protect Mode

Next, the timing is selected that will give the second burner an opportunity to light-off given the possible delays between burners. This timing is in addition to the PFEP/MFEP. In this example, we added 10 seconds.

Name	Register Number	Setting	Help
Ignitor duration	126	Normal duration	Help
Ignition type	127	Interrupted pilot	Help
Flame sensing system type	128	Combined S1 S2	Help
Secondary flame sensing time	129	10	Help
Pilot valve hold enable	131	Disable	Help
Pilot valve hold transition time	132	10	Help
Manual open switch enable	133	Disable	Help
Auto ignition enable	134	Disable	Help
Delayed main valve 2 enable	135	Disabled	Help
Combination flame sensing	265	Not Combined	Help

Protect Mode  
   
   
   
   
 << Previous  
 Next >>

The next configuration selection is the “OR” or “AND” logic in which the amplifiers/sensors will function.

**S1 OR S2-both required-** This configuration is redundant in that either of the two sensors sensing flame is sufficient to maintain the burner(s) firing. Both amplifier modules must be present on the bus at all times.

**S1 OR S2-one required-** This configuration is redundant in that either of the two sensors sensing flame is sufficient to maintain the burner(s) firing. Only one amplifier module must be present on the bus at all times to keep the burner(s) firing. This configuration allows for the automatic transition to a single flame sensor should an amplifier fail.

**S1 AND S2-** This configuration requires that both sensors sense flame at all times. If either sensor loses flame, the burner(s) shut down.

Name	Register Number	Setting	Help
Ignitor duration	126	Normal duration	Help
Ignition type	127	Interrupted pilot	Help
Flame sensing system type	128	Single flame sensor	Help
Secondary flame sensing time	129	0	Help
Pilot valve hold enable	131	Disable	Help
Pilot valve hold transition time	132	10	Help
Manual open switch enable	133	Disable	Help
Auto ignition enable	134	Disable	Help
Delayed main valve 2 enable	135	Disabled	Help
Combination flame sensing	265	Not Combined Not Combined S1 OR S2 - both required S1 OR S2 - one required S1 AND S2	Help

Protect Mode  
   
   
 Previous  
 Next >>

In this configuration “AND” logic is required as both flame sensors must sense flame for the burners to keep firing. If either flame is lost, both burners will stop firing.

Name	Register Number	Setting	Help
Ignitor duration	126	Normal duration	Help
Ignition type	127	Interrupted pilot	Help
Flame sensing system type	128	Single flame sensor	Help
Secondary flame sensing time	129	0	Help
Pilot valve hold enable	131	Disable	Help
Pilot valve hold transition time	132	10	Help
Manual open switch enable	133	Disable	Help
Auto ignition enable	134	Disable	Help
Delayed main valve 2 enable	135	Disabled	Help
Combination flame sensing	265	S1 AND S2	Help

Protect Mode

Finally, the amplifier details must be selected. For each amplifier specify the type and the threshold setting. Notice the Flame Failure Response Time is set once for both amplifiers.

Name	Register Number	Setting	Help
Flame failure response time	130	3 seconds	Help
Flame amplifier 1 required type	648	Rectification Ampli-Check	Help
Flame amplifier 1 flame thresho	649	0.8	Help
Flame amplifier 1 weak flame th	650	1.2	Help
Flame amplifier 2 required type	655	UV Ampli-Check	Help
Flame amplifier 2 flame thresho	656	0.8	Help
Flame amplifier 2 weak flame th	657	1.2	Help
Flame amplifier 3 required type	662	None	Help
Flame amplifier 3 flame thresho	663	0.8	Help
Flame amplifier 3 weak flame th	664	1.2	Help
Flame amplifier 4 required type	669	None	Help
Flame amplifier 4 flame thresho	670	0.8	Help
Flame amplifier 4 weak flame th	671	1.2	Help

Protect Mode